



TECNOFLUID

E N G I N E E R I N G



HYDRAULIC LOCK CYLINDERS CB TYPE

The hydraulic lock cylinders of the CB series complete the wide range of special cylinders manufactured by our company for a variety of industrial sectors.

The CB hydraulic lock cylinders meet the demand for small-sized pressing devices delivering considerable pushing force.

Due to their small overall dimensions (their main characteristic), according to the model, these cylinders can be used to lock small, medium or large-sized pieces. They can also be used for riveting, bending, marking or assembly works. They are manufactured in two versions (simple or double-acting), with a threaded external body and a smooth or tapped through hole, according to the model. Cylinders can be secured (according to their model) using the thread available on the body, through the tapped holes on the body (flanged connection) or the through holes on the body.

The CB hydraulic lock cylinders by Tecnofluid meet the strictest reliability requirements, also under heavy duty, whenever precise pushes and considerable work loads are required.

Technical characteristics:

Maximum pressure: 200 ÷ 320 bar (based on the model)

Fluid temperature: -20 ÷ +80°C

Recommended fluid: Mineral Hydraulic oil / phosphoric esters

Cylinders with threaded body – spring return (Series CB 01)**Max working pressure: 200 bar****TECHNICAL DATA**

Single-acting cylinders
Used with oil only
5-15-25 mm strokes

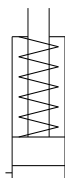

MODEL	Strength at 200 bar in Kgf.	Stroke in mm. H	Oil volume in cm ³	Piston area in cm ²	Oil infeed R
CB 01 201405	307	5	0.76	1.53	R 1/8" G
CB 01 201415		15	2.30		
CB 01 201425		25	3.80		
CB 01 302205	760	5	1.80	3.80	R 1/8" G
CB 01 302215		15	5.70		
CB 01 302225		25	9.50		

DESCRIPTION

Small-sized pushing piston, with threaded body, for easy connection to the equipment.

APPLICATIONS

Owing to their reduced overall dimensions and considerable pushing force, they are highly recommended to lock small and medium-sized items. They can be provided complete with supports, ring nuts and tips. As a rule they are driven by pressure multipliers or hydraulic power units.

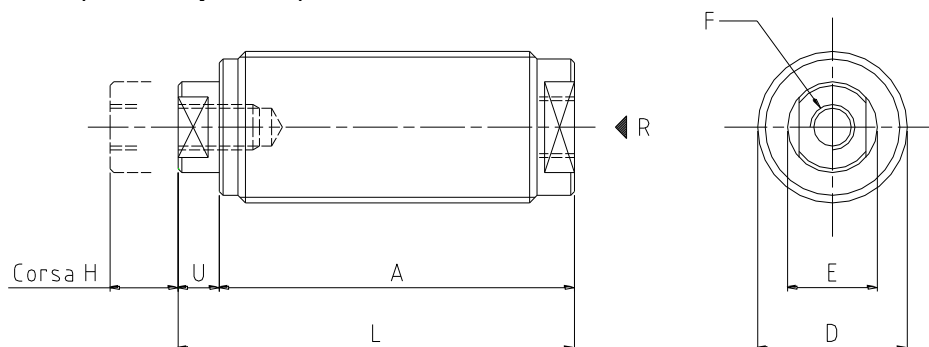
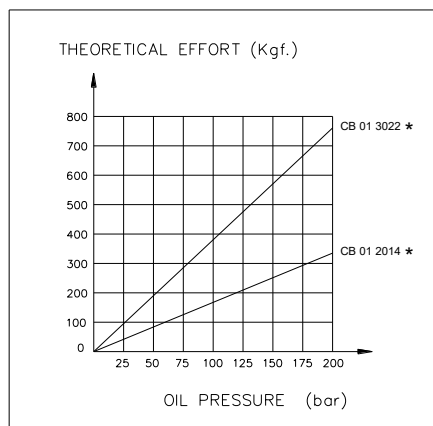
**DIAGRAM**

MODEL	DIMENSIONS					
	A	D	E	F	L	U
CB 01 201405 CB 01 201415 CB 01 201425	46 79 108	M 20 x 1.5	14	M 6 x 10	52 85 114	6
CB 01 302205 CB 01 302215 CB 01 302225	57 77 110	M 30 x 1.5	22	M 8 x 10	64 84 117	7

Cylinders with threaded body – spring return (Series CB 02)

Max working pressure: 320 bar

Single-acting cylinders
Used with oil only
15-25-50 mm strokes

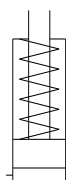

TECHNICAL DATA

MODEL	Strength at 320 bar in Kgf.	Stroke in mm. H	Oil volume in cm ³	Piston area in cm ²	Oil infeed R
CB 02 361815 CB 02 361825	1968	15 25	9.20 15.40	6.15	R 1/8" G
CB 02 401815 CB 02 401825	2569	15 25	12.00 20.00	8.03	R 1/4" G
CB 02 481825 CB 02 481850	3436	25 50	26.80 53.60	10.74	R 1/4" G
CB 02 682525 CB 02 682550	8160	25 50	63.80 127.60	25.50	R 3/8" G

DESCRIPTION

Small-sized pushing piston, with threaded body, for easy connection to the equipment.

APPLICATIONS

Owing to their reduced overall dimensions and considerable pushing force, they are highly recommended to clamp medium and large-sized items. They are also used for riveting, bending, marking and assembly works. They can be provided complete with support bases, ring nuts and tips. As a rule they are driven by pressure multipliers or hydraulic power units.

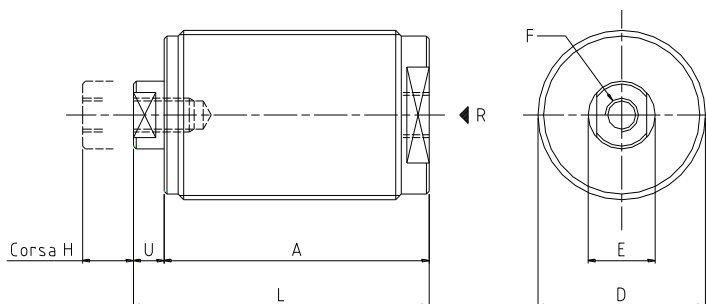

DIAGRAM

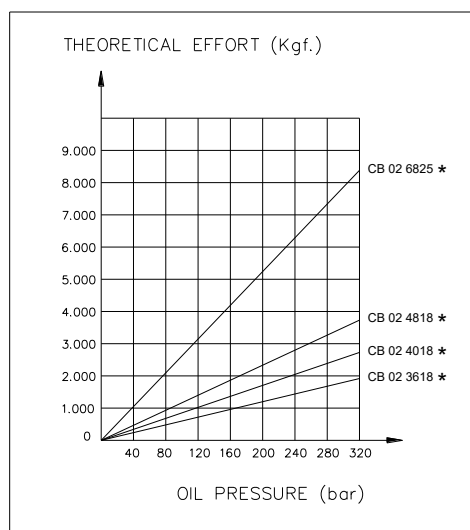

MODEL	DIMENSIONS					
	A	D	E	F	L	U
CB 02 361815 CB 02 361825	74 100	M 36 x 1.5	18	M 8 x 12	81 107	7
CB 02 401815 CB 02 401825	83 113	M 40 x 1.5	18	M 8 x 12	90 120	7
CB 02 481825 CB 02 481850	116 153	M 48 x 1.5	18	M 10 x 15	123 160	7
CB 02 682525 CB 02 682550	130 175	M 68 x 2.0	25	M 12 x 15	138 183	8

Cylinders with smooth through hole – smooth body – spring return (Series CB 03)

Max working pressure: 320 bar

TECHNICAL DATA

Single-acting cylinders
Used with oil only
6-12mm stroke.

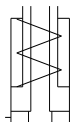

MODEL	Strength at 320 bar in Kgf.	Stroke in mm. H	Oil volume in cm ³	Piston area in cm ²	Oil infeed R
CB 03 504006 CB 03 504012	3206	6 12	6.01 12.02	10.02	R 1/8" G
CB 03 705706 CB 03 705712	6710	6 12	12.36 24.72	20.97	R 1/8" G R 1/4" G
CB 03 857006 CB 03 857012	10345	6 12	19.38 38.76	32.33	R 1/4" G

DESCRIPTION

Pushing or pulling lock piston, provided with a smooth through hole, to fit threaded easy-to-adjust pins or tie rods.

APPLICATIONS

Used for pushing or pulling. In the first case, fit properly shaped heads into the central hole. For rear clamping, use the holes on the lower base of the cylinder. It can be installed on multiple units, and in any position. As a rule they are driven by pressure multipliers or hydraulic power units.

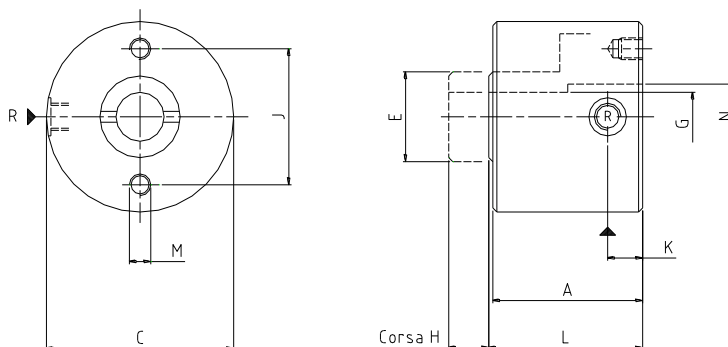

DIAGRAM

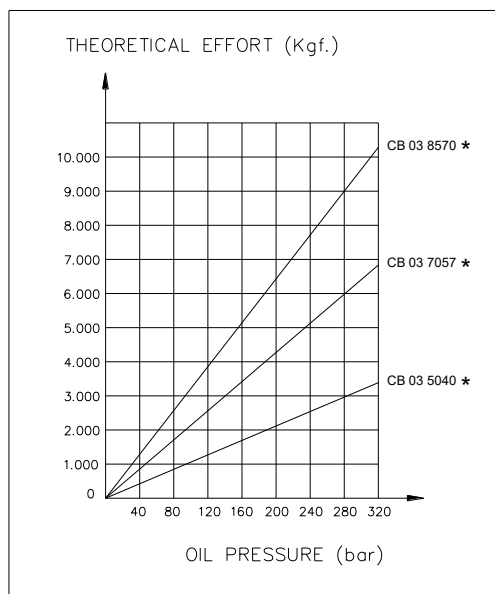

MODEL	DIMENSIONS								
	A	C	E	G	J	K	L	M	N
CB 03 504006 CB 03 504012	50 80	50	24	12	35	8	50.5 80.5	M 6 x 9	18
CB 03 705706 CB 03 705712	52 80	70	35	18	50	8.5 10.5	52.5 80.5	M 8 x 10	24
CB 03 857006 CB 03 857012	62 80	85	40	20	50	10.5	62.5 80.5	M 8 x 10	28

Cylinders with tapped through hole – threaded body – spring return (Series CB 04)

Max working pressure: 320 bar

TECHNICAL DATA

Single-acting cylinders
Used with oil only
6-12mm stroke.

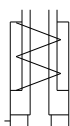

MODEL	Strength at 320 bar in Kgf.	Stroke in mm. H	Oil volume in cm ³	Piston area in cm ²	Oil infeed R
CB 04 484006 CB 04 484012	3206	6 12	6,01 12,02	10,02	R 1/8" G
CB 04 685706 CB 04 685712	6710	6 12	12,36 24,72	20,97	R 1/8" G R 1/4" G
CB 04 837006 CB 04 837012	10345	6 12	19,38 38,76	32,33	R 1/4" G

DESCRIPTION

Pushing or pulling lock piston, provided with a tapped through hole, to fit threaded easy-to-adjust tie rods. Threaded body.

APPLICATIONS

Used for pushing or pulling. In the first case, fit properly shaped heads into the central hole. For rear clamping, use the holes on the lower base of the cylinder. It can be installed on multiple units, and in any position. As a rule they are driven by pressure multipliers or hydraulic power units.

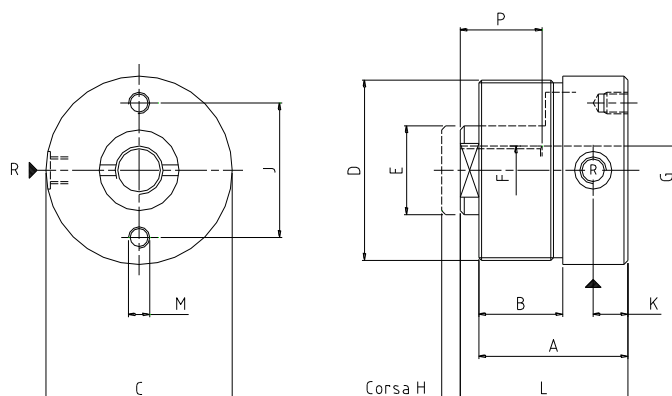

DIAGRAM

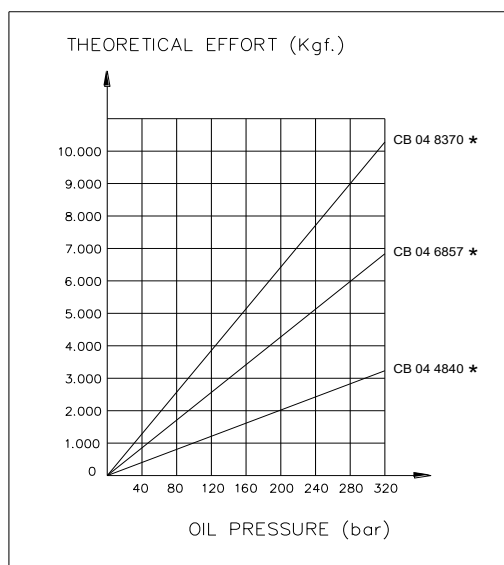

MODEL	DIMENSIONS					
	A	B	C	D	E	F
CB 04 484006 CB 04 484012	50 80	30 45	50	M 48 x 1.5	24	M 12
CB 04 685706 CB 04 685712	58 64	30 36	70	M 68 x 2	35	M 18

CB 04 837006 CB 04 837012	62 80	35 45	85	M 83 x 2	40	M 20
------------------------------	----------	----------	----	----------	----	------

MODEL	DIMENSIONS					
	G	J	K	L	M	P
CB 04 484006 CB 04 484012	12	35	8	56 86	M 6 x 9	22 40
CB 04 685706 CB 04 685712	18.5	50	8	64 70	M 8 x 10	30.5
CB 04 837006 CB 04 837012	20	50	10.5	68 86	M 8 x 10	27 40

Pull cylinders - threaded body – spring return (Series CB 06)

Max working pressure: 320 bar

TECHNICAL DATA

Single-acting cylinders
Used with oil only
10-25 mm stroke

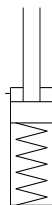

MODEL	Strength at 320 bar in Kgf.	Stroke in mm. H	Oil volume in cm ³	Piston area in cm ²	Oil infeed R
CB 06 362810 CB 06 362825	1478	10 25	4.62 11.55	4.62	R 1/8" G
CB 06 483710 CB 06 483725	2624	10 25	8.20 20.50	8.2	R 1/8" G
CB 06 685710 CB 06 685725	6595	10 25	20.61 51.52	20.61	R 1/4" G

DESCRIPTION

The piston of these cylinders moves inwards, and generates a pulling force. The body is threaded for easy assembly, and is provided with 4 tapped holes for flange connection.

APPLICATIONS

These cylinders are used for traditional numeric control or transfer machinery/equipment, and can be assembled in any position, either alone or in batteries, and are driven by pressure multipliers or hydropneumatic power units.

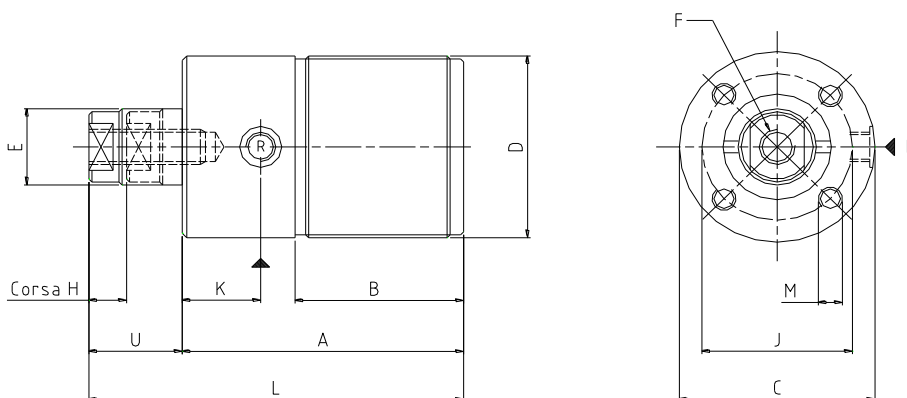

DIAGRAM

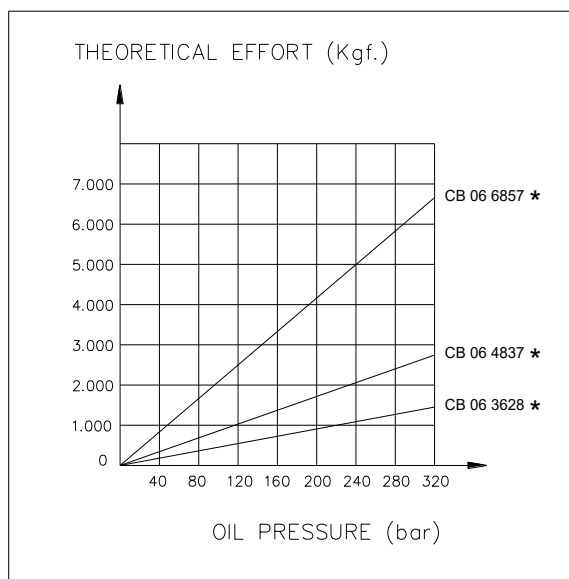

MODEL	DIMENSIONS				
	A	B	C	D	E
CB 06 362810 CB 06 362825	85 100	47 63	36	M 36 x 1.5	14
CB 06 483710 CB 06 483725	85 100	53 68	48	M 48 x 1.5	18
CB 06 685710 CB 06 685725	100 115	58 74	68	M 68 x 2	25

MODEL	DIMENSIONS					
	F	K	J	L	M	U
CB 06 362810 CB 06 362825	M 8 x 15	28	28	103 135	M 6 x 10	20 35
CB 06 483710 CB 06 483725	M 10 x 20	25	37	105 135	M 6 x 12	20 35
CB 06 685710 CB 06 685725	M 14 x 20	32	50	120 150	M 8 x 15	20 35

Double-acting cylinders – threaded body (Series CB 08)

Max working pressure: 250 bar

TECHNICAL DATA

Double-acting cylinders
Used with oil only
25-50-80-100 mm strokes

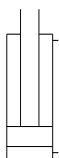

MODEL	Strength at 250 bar in Kgf.		Stroke in mm. H	Oil volume in cm ³		Piston area in cm ²		Oil infeed R
	Push	Pull		Push	Pull	Push	Pull	
CB 08 362525 CB 08 362550 CB 08 362580 CB 08 3625100	1225	840	25	12.25	8.42	4.9	3.37	R 1/8" G
50			24.50	16.85				
80			39.20	26.96				
100			49.00	33.80				
CB 08 483525 CB 08 483550 CB 08 483580 CB 08 4835100	2405	1770	25	24.05	17.70	9.62	7.08	R 1/4" G
50			48.10	35.40				
80			76.96	56.65				
100			96.20	70.80				
CB 08 685550 CB 08 685580 CB 08 6855100	5937	4712	50	118.75	94.25	23.75	18.85	R 3/8" G
80			190.99	150.80				
100			237.50	188.50				

DESCRIPTION

Double-acting short-stroke cylinders, with threaded body, for easy installation and positioning on specific equipment.

APPLICATIONS

These cylinders are used to manufacture shearing, pressing and piercing tools, for thin sheets or pipes. As a rule they are driven by hydropneumatic or hydraulic power units.

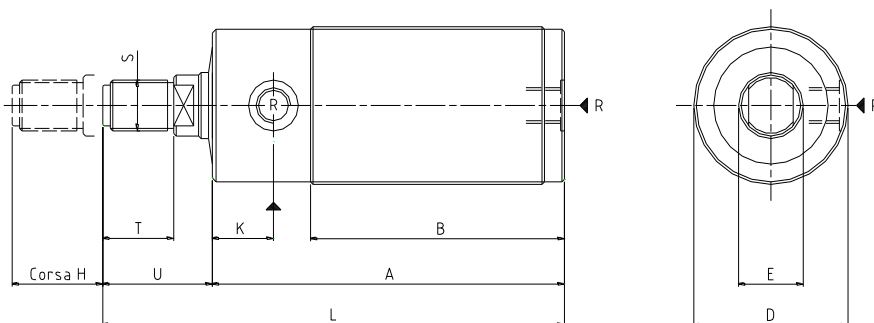

DIAGRAM

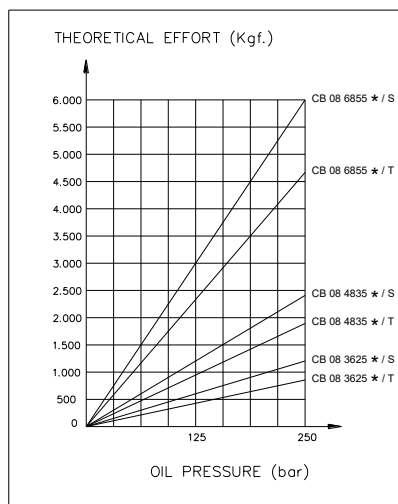

/ T = Pull effort
/ S = Push effort

MODEL	DIMENSIONS								
	A	B	D	E	K	L	S	T	U
CB 08 362525	121	93	M 36 x 1.5	14	18	145	M 10 x 1.25	14	24
CB 08 362550	146	118				170			
CB 08 362580	176	148				200			
CB 08 3625100	196	168				220			
CB 08 483525	130	95	M 48 x 1.5	18	22	160	M 14 x 1.5	18	30
CB 08 483550	155	120				185			
CB 08 483580	185	150				215			
CB 08 4835100	205	170				235			
CB 08 685550	175	132	M 68 x 2	25	28	213	M 20 x 1.5	25	38
CB 08 685580	205	162				243			
CB 08 6855100	225	182				263			

Spring lock cylinder – hydraulic release (Series CB 09)

Max working pressure: 200 bar

TECHNICAL DATA

Single-acting cylinders
Used with oil only
Threaded body

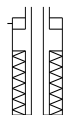

MODEL	Strength at 200 bar in Kgf.	Stroke in mm. H	Oil volume in cm ³	Piston area in cm ²	Oil infeed R
CB 09 48	1100	2,7	2,3	8,20	R 1/8" G
CB 09 68	2500	3,7	5,3	14,20	

DESCRIPTION

Piston with partially tapped through hole. Threaded body for pre-loading a series of Belleville springs, built-into the cylinder, for a considerable locking force. To release it, inject oil under pressure into the cylinder.

APPLICATIONS

These cylinders are highly recommended to permanently lock guides, tailstocks, heads of machine tools. They are used also to lock moulds and matrixes or pieces on pallets, and whenever a constant locking force is required indefinitely, without holding the connection pressed continuously, by means of multipliers or power units. The central tapped hole makes it possible to install easily adjustable threaded tie rods. It can be mounted in any position.

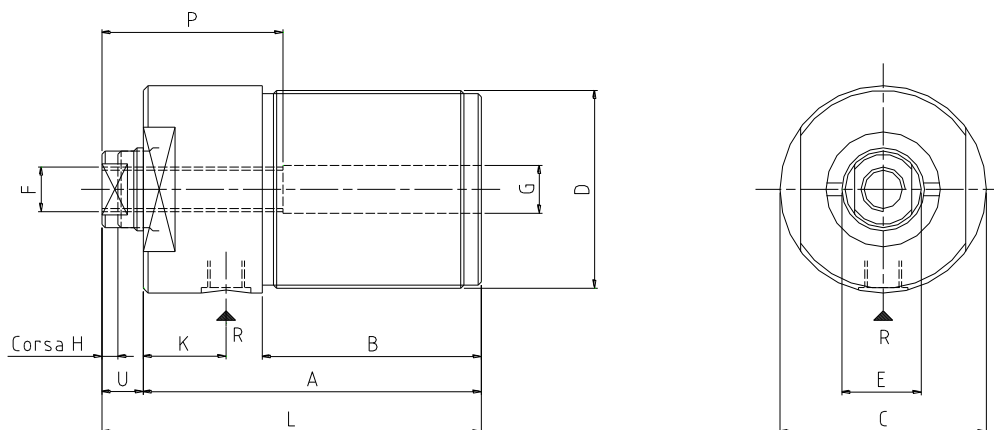

DIAGRAM

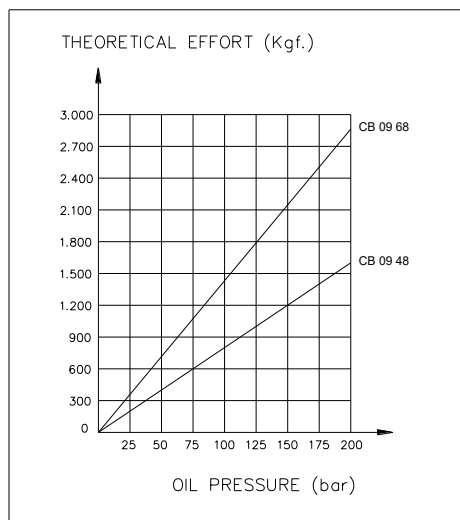

MODEL	DIMENSIONS				
	A	B	C	D	E
CB 09 48	86	58	50	M 48 x 1,5	18
CB 09 68	120	85	60	M 60 x 2	22

MODEL	DIMENSIONS					
	F	G	K	L	P	U
CB 09 48	M 10 x 1,5	10.1	19	94	40	8
CB 09 68	M 16 x 2	16.1	19	129	40	9

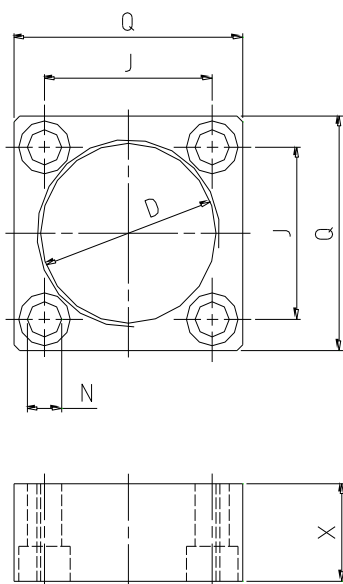
Support bases**SQUARE SUPPORT BASES**

MODEL	DIMENSIONS				
	D	J	N	Q	X
BQ 36	M 36 x 1,5	38	9	50	20
BQ 48	M 48 x 1,5	44	9	60	25
BQ 68	M 68 x 2	64	11	80	30

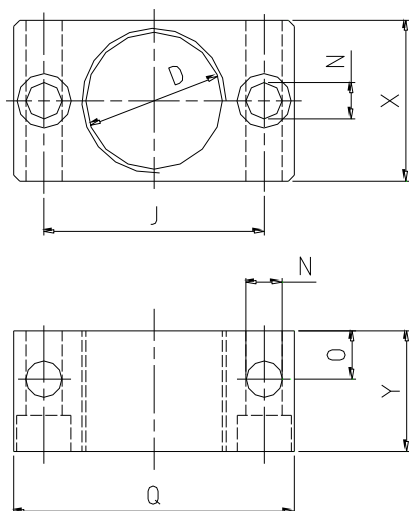
RECTANGULAR SUPPORT BASES

MODEL	DIMENSIONS						
	D	J	N	O	Q	X	Y
BS 20	M 20 x 1.5	35	7	10	50	25	30
BS 30	M 30 x 1.5	50	9	12	70	40	
BS 36	M 36 x 1.5	55			80	50	40
BS 40	M 40 x 1.5	60			90	60	
BS 48	M 48 x 1.5	70	11	15	110	80	50
BS 68	M 68 x 2	90					

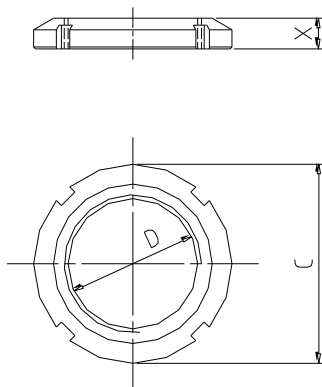
Ring nuts - Tips**RING NUTS**

MODEL	DIMENSIONS		
	C	D	X
GF 20	28	M 20 x 1.5	5
GF 30	45	M 30 x 1.5	7
GF 36	52	M 36 x 1.5	8
GF 40	58	M 40 x 1.5	9
GF 48	68	M 48 x 1.5	10
GF 68	85	M 68 x 2	12

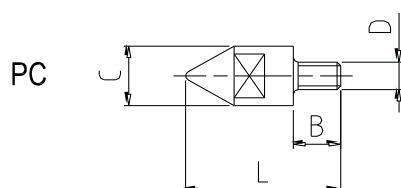
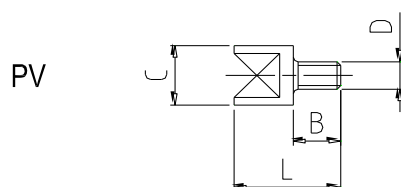
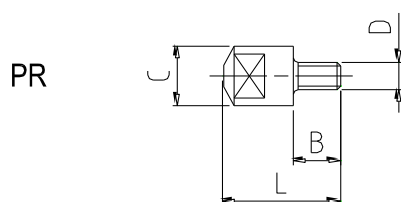
TIPS

MODEL	DIMENSIONS			
	B	C	D	L
PR 1306 PC 1306 PV 1306	10	13	M 6	20 25 20
PR 1708 PC 1708 PV 1708	12	17	M 8	27 32 27

TECNOFLUID ENGINEERING srl Via Dei Mille,2/C 20811 CESANO MADERNO (MB) ITALY

TEL. 0362.645981 FAX 0362.645999 e-mail info@tecnofluid.info www.tecnofluid.info